

C-LOK

C-LOK Instrument Valve Co.,Ltd.

Syphons



C-LOK

Contents

01 W1 Series

04 W2 Series

05 W3 Series

Features

- Maximum working temperature is 850°F (454 °C).
- Maximum working pressure is 6000 psig (414 bar). Multiply the working pressure by the elevated temperature factors to get the working pressure at elevated temperature. To know the elevated temperature factor, please refer to the related information of C-LOK Tube Fittings in page 9.
- Standard materials is 316 SS and 304 SS, other materials are available upon request.

Material Specifications

Component	Material Specifications
Tube	316L or 304L/A269
Connector	316 or 304/A276

Ordering Information

Add the material designator as prefix to the basic ordering number (SS for 316 SS, S4 for 304 SS).
Example: SS-W1-MG8-10x2

W1 Series

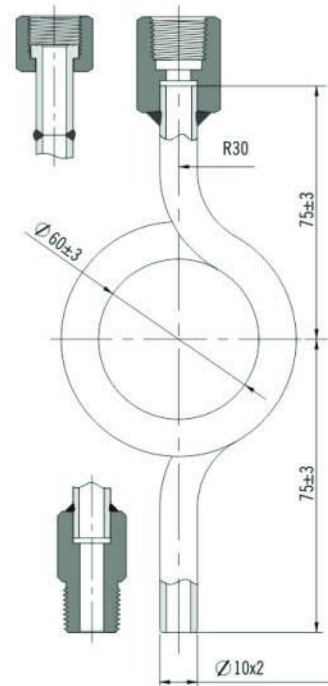

Basic Ordering Number	End Types and Size	
	Top End	Other End
W1 Series		
-W1-M6	3/8 Male NPT	3/8 Male NPT
-W1-M6-F4	3/8 Male NPT	1/4 Female NPT
-W1-MG6-FG4	3/8 Male ISO Parallel Thread	1/4 Female ISO Parallel Thread
-W1-MG6-MG4	3/8 Male ISO Parallel Thread	1/4 Male ISO Parallel Thread
-W1-F8	1/2 Female NPT	1/2 Female NPT
-W1-F8-F4	1/2 Female NPT	1/4 Female NPT
-W1-F8-FG8	1/2 Female NPT	1/2 Female ISO Parallel Thread
-W1-F8-FG4	1/2 Female NPT	1/4 Female ISO Parallel Thread
-W1-F8-FM20	1/2 Female NPT	M20x1.5 Female ISO
-W1-F8-SW8	1/2 Female NPT	1/2 Tube socket Weld
-W1-FM20	M20x1.5 Female ISO	M20x1.5 Female ISO
-W1-FM20-FM10	M20x1.5 Female ISO	M10x1 Female ISO
-W1-FG8-FM20	1/2 Female ISO Parallel Thread	M20x1.5 Female ISO
-W1-FG8-MB10	1/2 Female ISO Parallel Thread	10x2
-W1-MB10	10x2	10x2
-W1-M8	1/2 Male NPT	1/2 Male NPT
-W1-M8-F4	1/2 Male NPT	1/4 Female NPT
-W1-MG8-MG4	1/2 Male ISO Parallel Thread	1/4 Male ISO Parallel Thread
-W1-MG8-FG4	1/2 Male ISO Parallel Thread	1/4 Male ISO Parallel Thread
-W1-MM20-FM20	M20x1.5 Male ISO	M20x1.5 Female ISO

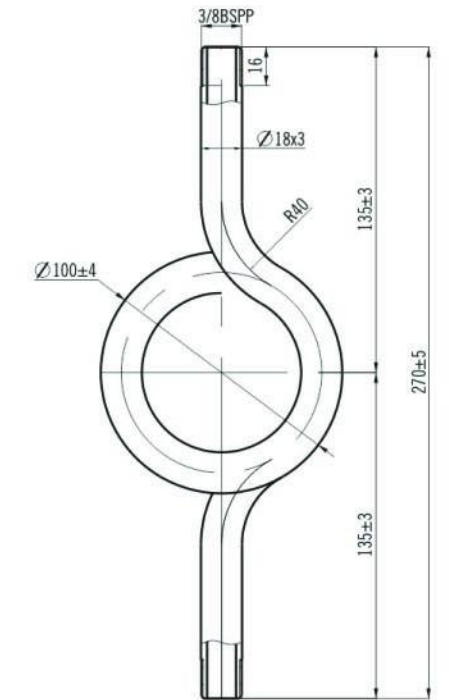
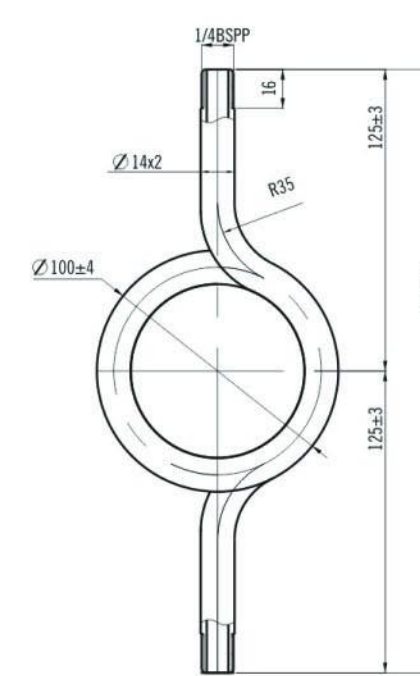

Basic Model Number	Inlet	Outlet
SS-W1-MG4-14X2	1/4" Male BSPP	1/4" Male BSPP

Basic Model Number	Inlet	Outlet
SS-W1-MG6-18X3	3/8" Male BSPP	3/8" Male BSPP

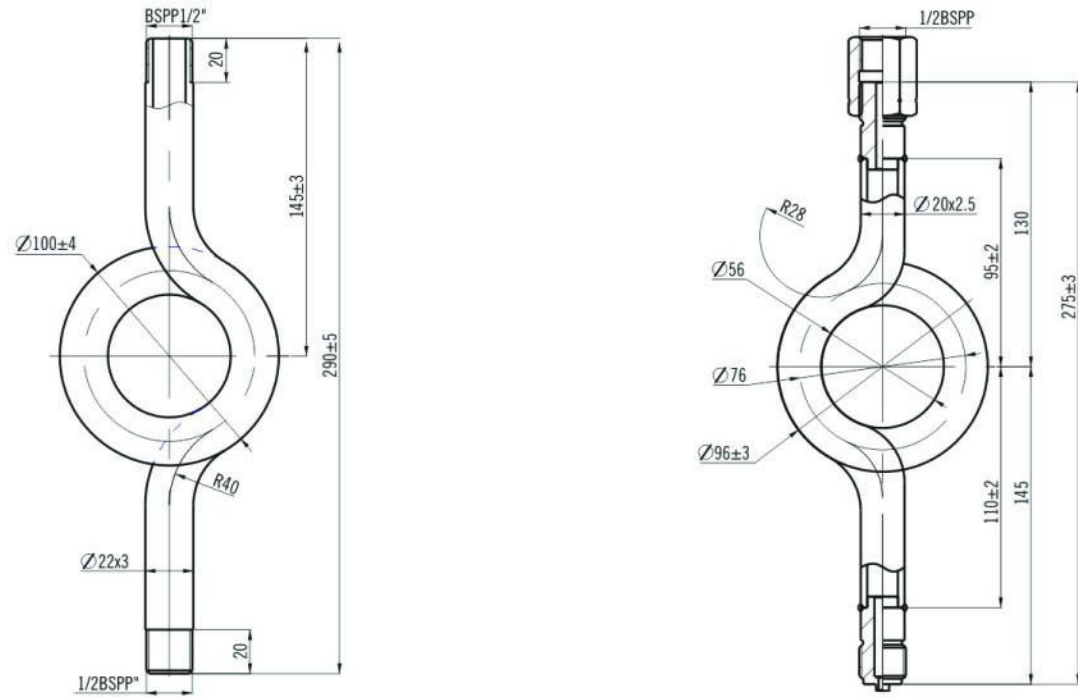

Basic Model Number	Inlet	Outlet
SS-W1-MG8-22x3	1/2" Male BSPP	1/2" Male BSPP

Basic Model Number	Inlet	Outlet
SS-W1-MG8-FG8-20x2.5	1/2" Male BSPP	1/2" Female BSPP

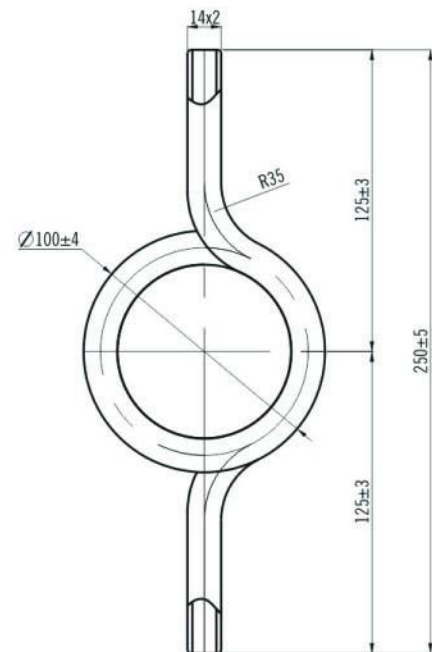

Basic Model Number	Inlet	Outlet
SS-W1-MB14-14X2	14mm Metric Tube Butt Weld	14mm Metric Tube Butt Weld

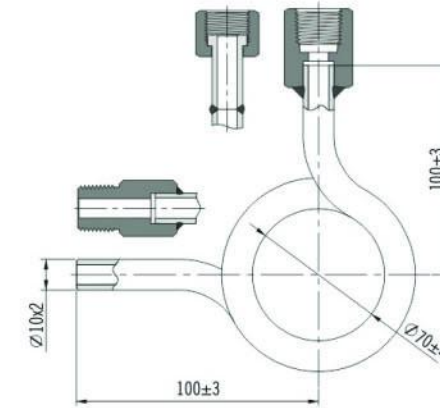

Basic Ordering Number	End Types and Size	
	Top End	Other End
-W2-M6	3/8 Male NPT	3/8 Male NPT
-W2-M6-F4	3/8 Male NPT	1/4 Female NPT
-W2-MG6-FG4	3/8 Male ISO Parallel Thread	1/4 Female ISO Parallel Thread
-W2-MG6-MG4	3/8 Male ISO Parallel Thread	1/4 Male ISO Parallel Thread
-W2-F8	1/2 Female NPT	1/2 Female NPT
-W2-F8-F4	1/2 Female NPT	1/4 Female NPT
-W2-F8-FG8	1/2 Female NPT	1/2 Female ISO Parallel Thread
-W2-F8-FG4	1/2 Female NPT	1/4 Female ISO Parallel Thread
-W2-F8-FM20	1/2 Female NPT	M20x1.5 Female ISO
-W2-F8-SW8	1/2 Female NPT	1/2 Tube socket Weld
-W2-F8-MS10	1/2 Female NPT	10mm Tube socket Weld
-W2-FM20	M20x1.5 Female ISO	M20x1.5 Female ISO
-W2-FM20-FM10	M20x1.5 Female ISO	M10x1 Female ISO
-W2-FM20-MB10	M20x1.5 Female ISO	10x2
-W2-FG8-FM20	1/2 Female ISO Parallel Thread	M20x1.5 Female ISO
-W2-FG8-MB10	1/2 Female ISO Parallel Thread	10x2
-W2-MB10	10x2	10x2
-W2-M8	1/2 Male NPT	1/2 Male NPT
-W2-M8-F4	1/2 Male NPT	1/4 Female NPT
-W2-MG8-MG4	1/2 Male ISO Parallel Thread	1/4 Male ISO Parallel Thread
-W2-MG8-FG4	1/2 Male ISO Parallel Thread	1/4 Male ISO Parallel Thread
-W2-MM20-MM20	M20x1.5 Male ISO	M20x1.5 Male ISO

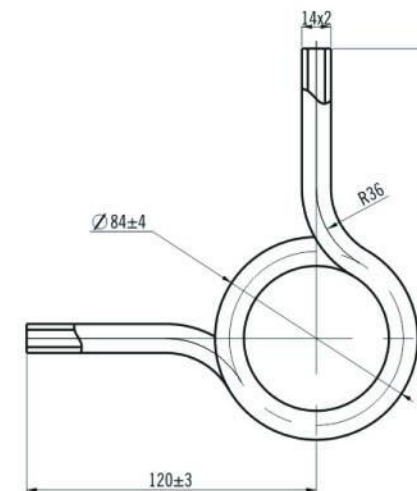

Basic Model Number	Inlet	Outlet
SS-W2-MB14-14X2	14mm Metric Tube Butt Weld	14mm Metric Tube Butt Weld

W3 Series

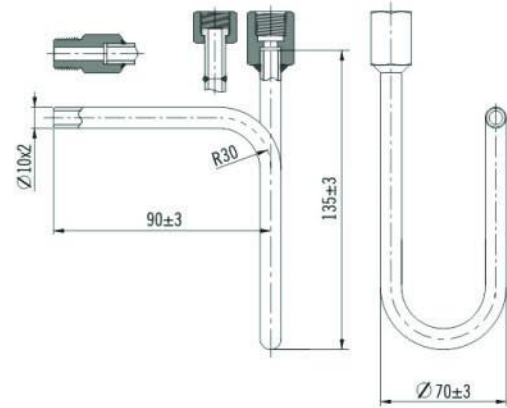

Basic Ordering Number	End Types and Size	
	Top End	Other End
W1 Series		
-W3-M6	3/8 Male NPT	3/8 Male NPT
-W3-M6-F4	3/8 Male NPT	1/4 Female NPT
-W3-MG6-FG4	3/8 Male ISO Parallel Thread	1/4 Female ISO Parallel Thread
-W3-MG6-MG4	3/8 Male ISO Parallel Thread	1/4 Male ISO Parallel Thread
-W3-M6-MS10	3/8 Male NPT	10mm Tube socket Weld
-W3-F8	1/2 Female NPT	1/2 Female NPT
-W3-F8-F4	1/2 Female NPT	1/4 Female NPT
-W3-F8-FG8	1/2 Female NPT	1/2 Female ISO Parallel Thread
-W3-F8-FG4	1/2 Female NPT	1/4 Female ISO Parallel Thread
-W3-F8-FM20	1/2 Female NPT	M20x1.5 Female ISO
-W3-F8-FM10	1/2 Female NPT	M10x1 Female ISO
-W3-F8-SW8	1/2 Female NPT	1/2 Tube socket Weld
-W3-F8-MS10	1/2 Female NPT	10mm Tube socket Weld
-W3-FM20	M20x1.5 Female ISO	M20x1.5 Female ISO
-W3-FM20-FM10	M20x1.5 Female ISO	M10x1 Female ISO
-W3-FM20-MB10	M20x1.5 Female ISO	10x2
-W3-FG8-FM20	1/2 Female ISO Parallel Thread	M20x1.5 Female ISO
-W3-FG8-FM10	1/2 Female ISO Parallel Thread	M10x1 Female ISO
-W3-FG8-MB10	1/2 Female ISO Parallel Thread	10x2
-W3-MB10	10x2	10x2
-W3-M8	1/2 Male NPT	1/2 Male NPT
-W3-M8-F4	1/2 Male NPT	1/4 Female NPT
-W3-MG8-MG4	1/2 Male ISO Parallel Thread	1/4 Male ISO Parallel Thread
-W3-MG8-FG4	1/2 Male ISO Parallel Thread	1/4 Female ISO Parallel Thread
-W3-MM20-FM20	M20x1.5 Male ISO	M20x1.5 Female ISO

W3 Series

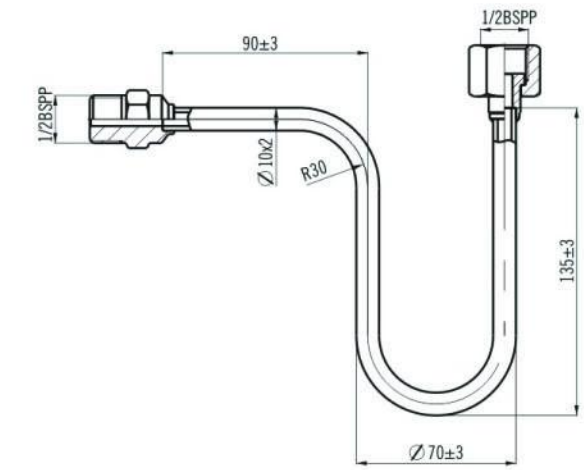
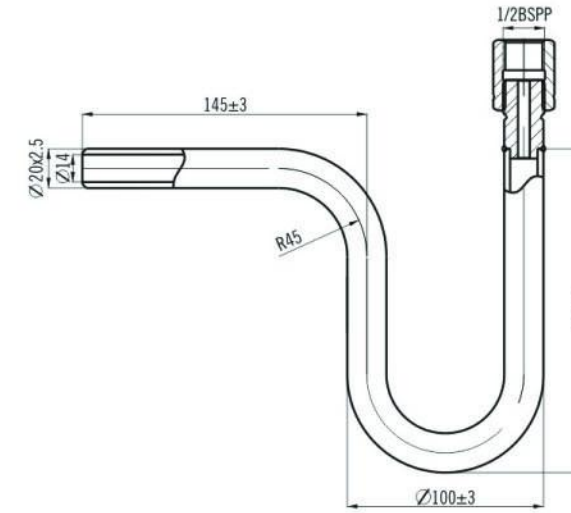

Basic Model Number	Inlet	Outlet
SS-W3-MB20-FG8-20x2.5	20mm Metric Tube Butt Weld	1/2" Female BSPP

Basic Model Number	Inlet	Outlet
SS-W3-MG8-FG8-10x2	1/2" Male BSPP	1/2" Female BSPP

W3 Series

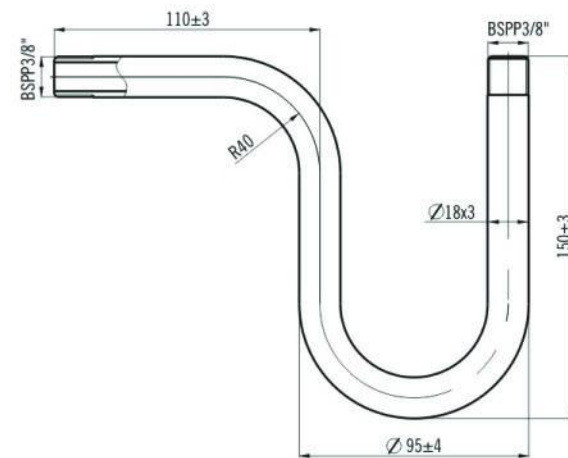
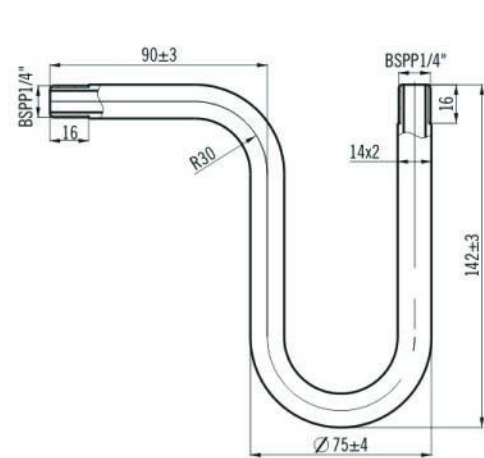

Basic Model Number	Inlet	Outlet
SS-W3-MG4-14x2	1/4" Male BSPP	1/4" Male BSPP

Basic Model Number	Inlet	Outlet
SS-W3-MG6-18x3	3/8" Male BSPP	3/8" Male BSPP

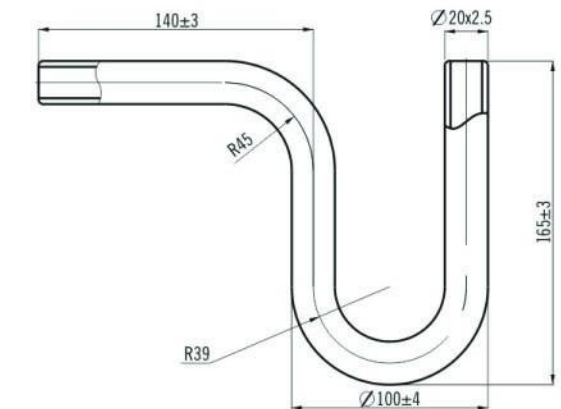
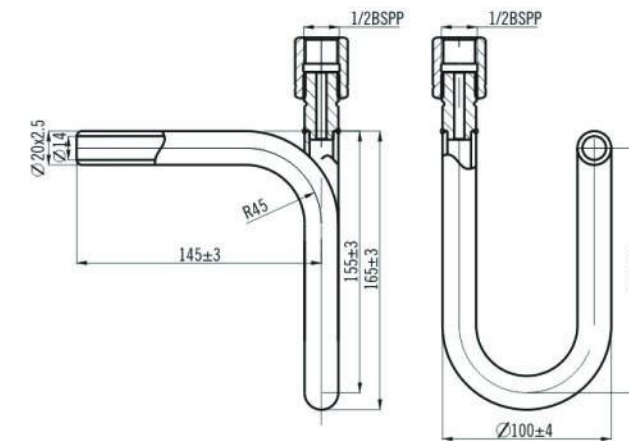

Basic Model Number	Inlet	Outlet
SS-W3-MB20-FG8-20x2.5	20mm Metric Tube Butt Weld	1/2" Female BSPP

Basic Model Number	Inlet	Outlet
SS-W3-MB20-20x2.5	20mm Metric Tube Butt Weld	20mm Metric Tube Butt Weld